

Whirlpool Bathtub

Installation & Operation Instructions

503 Railroad Ave. Glenwood, IA 51534-2001 ☐(712) 527-1800 FAX (712) 527-4331 Customer Toll Free (800)795-1812

General Information

Upon receipt, immediately inspect the tub to make sure the unit has shipped as ordered and has arrived undamaged. If a problem is discovered, call Manufacturer immediately. Handling damages are not covered under warranty. Protect the tub during installation to prevent damage. Do not stand or place tools directly on the tub finish. Check pump unions, hand tighten only. Remember to water test the whirlpool system and plumbing before enclosing. Always refer to local building codes.

INSTRUCTIONS PERTAINING TO A RISK OF FIRE, ELECTRIC SHOCK, OR INJURY TO PERSONS

IMPORTANT SAFETY INSTRUCTIONS

Electrical Requirements

Pumps are pre-wired with leads that can be plugged into a grounded GFCI protected dedicated circuit of adequate amperage.

WARNING: When using electrical products, basic precautions should always be followed, including the following:

1. **DANGER: RISK OF ELECTRIC SHOCK.** The unit must be connected to a supply circuit that is protected by the installer and should be tested on a routine basis. To test the GFCI, push the test button. The GFCI should interrupt power. Push the reset button. Power should be restored. If the GFCI fails to operate in this manner, the GFCI is defective. If the GFCI interrupts power to the bathtub without the test button being pushed, a ground current is flowing, indicating the possibility of an electric shock. Do not use this hydromassage bathtub. Disconnect the hydromassage bathtub and have the problem corrected by a qualified service representative before using.
 2. A qualified service technician in accordance with all applicable local and national codes must perform all electrical wiring, service and repair. Failure to do so may pose electrical hazard.
 3. Before making any electrical connections, make certain that the electrical power is turned OFF at the circuit breaker, and take measures to ensure that it CANNOT accidentally be turned on again.
 4. Install in such a manner as to permit access for servicing. An approximate 14"x14" (35cm x 35cm) access door is recommended.
 5. Grounding is required. The unit shall be installed and grounded by a qualified service representative before using.
 6. For permanently connected units, a green colored terminal (or a wire connector marked "G", "GR", or "Grounding") is provided within the terminal compartment. To reduce the risk of shock, connect this terminal or connector to the grounding terminal of your electric service or supply panel with a conductor equivalent in size to the circuit conductor supplying this equipment.
 7. It is important that the wiring be safely completed. When cutting conduits, be sure to debur the edges and remove any sharp edges, which may cut or damage the wire. Use the proper electrical connectors and bushings for all installations.
 8. Building materials and wiring should be routed away from the pump body or other heat producing components of the system.
 9. The metal enclosure of all electric components, current collectors and other metal in contact with the tub water shall be bonded together by individual solid copper bonding conductors not smaller than #8AWG (8.4mm).
 10. Install to permit access for servicing.
- 11. SAVE THESE INSTRUCTIONS.**

Metal housing pump requirements: 1hp. = 120 volts, 7.5 amps; 1-1/4hp = 120 volts, 5.5 to 5.9 amps; 1-1/2hp. =120 volts, 16.5 amps. The metal enclosure of all electrical components, current collectors and other metal in contact with tub water shall be bonded together with individual solid copper bonding conductors not smaller than #8AWG (8.4mm). A grounding clamp is provided on the pump housing.

Composite housing pump requirements: 1-1/4hp. = 120 volts, 8.5 amps; 1-1/2hp. = 120 volts, 13.5 amps. Double insulated pumps do not need to be bonded.

Each pump is equipped with a thermal limiter that shuts off the entire unit, in the event the pump becomes overheated.

Units equipped with heaters

Whirlpools with **in-line heaters** need to be bonded, using solid copper bonding conductor not smaller than #8AWG (8.4mm).

WARNING

The heater must be connected to a supply circuit that is protected by a Ground-Fault Circuit-Interrupter (GFCI). The GFCI should be provided by the installer and should be tested on a routine basis.

Prolonged immersion in hotter water may induce Hyperthermia. The causes, systems, and effects of hyperthermia may be described as follows: Hyperthermia occurs when the internal temperature of the body reaches a level several degrees above normal body temperature of 98.6 degrees F. The symptoms of hyperthermia include: a) an increase in the internal temperature of the body, b) Dizziness, c) Fainting. The effects of hyperthermia include: a) Failure to perceive heat, b) Failure to recognize the need to exit the bath, c) Unawareness of impending hazard, d) Fetal damage in pregnant women, e) Physical inability to exit the bath, f) Unconsciousness resulting in the danger of drowning.

WARNING – Use of alcohol, drugs or medication can greatly increase the risk of hyperthermia.

High Limit protection: In the event the water temperature exceeds 104 degrees the heater will automatically shut-off. Once the water temperature drops below 104 degrees again, it will restart.

Pressure Switch: In the event the pump is not running or if there is not sufficient flow, the heater will not turn on. There is no on or off switch to the heater, if the pump is running the heater is on.

Plumbing Requirements

All whirlpools are filled in the same manner as a standard bathtub with an over-the-tub spout and 1 ½" drain. Certain units may require a longer spout. Check the specifications to locate the position of the floor cut out needed to hook up the drain on your specific model. The water heater capacity should be equal to the water capacity of the tub.

Framing Instructions

Framing is not recommended prior to receiving your whirlpool due to possible measurement

variances. After receiving the unit, measure the height of the unit from the floor to the tub lip. Build a support frame under all four lips slightly higher than the height of the tub itself. Add an additional 1/2" of height to allow the mortar and caulk to bridge any gaps between the floor and tub base or between the frame and tub lip (diagrams below). Remember that the support frame should be level in all directions to insure that the tub deck after installation is level. If the tub is not installed with a level deck, the tub bowl and piping may not drain properly. If your whirlpool unit is provided with a skirt, there is no need to build a support frame on the skirt side. The skirt will provide support to the tub lip. However, the other sides do have to be supported.

Access Panel Required: Sufficient clearance must be provided for access to service connections, pump and electrical hook-ups. A 14" x 14" access door is recommended.

When fittings (spout, handles, valves, etc.) are to be mounted on the unit, be certain that the hot and cold water copper supply lines are located where there is ample room for mounting **before** setting the unit in place.

Setting the Tub in Place

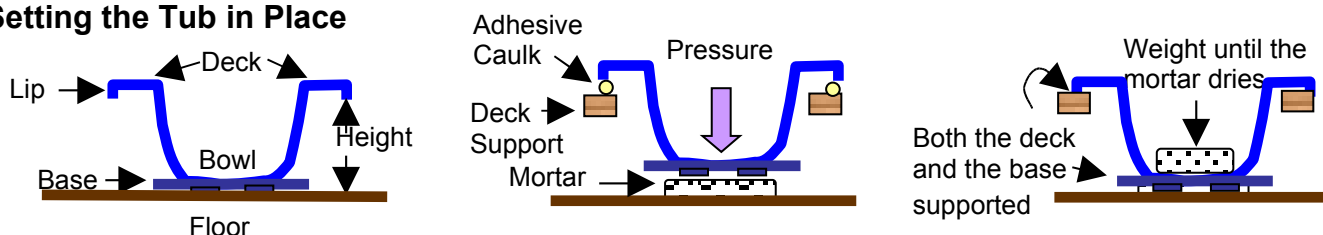

Build a level support frame as recommended. Put a bridging agent both on the floor and the deck support. Set the tub in place and apply pressure until the tub deck is firmly against the support frame. Leave some weight (approximately 50 lbs) in the tub until the mortar and adhesive caulk dry. This weight will prevent the tub from rising back up. If the tub bowl is not supported, the weight of the water and an occupant will eventually cause the tub to shift or crack. If the tub deck is not supported properly, it will flex causing the grout line to fail.

Incorrect Installations

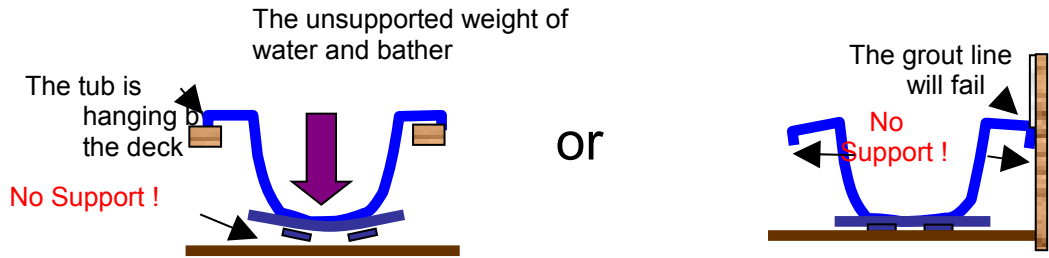

- Do not lift the tub by any portion of the plumbing or pump.
 - Do not stand in the tub during construction. To help protect your tub, place corrugated or other padded material on floor of whirlpool.
 - Do not put insulation around, or block airflow to pump. Pump will over heat and shut down.
 - Damage by incorrect installation is not covered under warranty.
 - Do not make any alterations, additions, or deletions to the whirlpool system, pump, or bathtub.
- Warning:** Whirlpool pump and piping are factory assembled. Relocation of pump or other modifications could adversely affect the performance and safe operation of the unit, and will void the warranty.

Illustrations

Platform Installation

Frame opening should be 2" less than the length and width of the tub to provide deck support

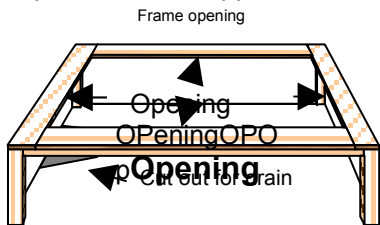

Build frame 1/2" higher than tub lip.

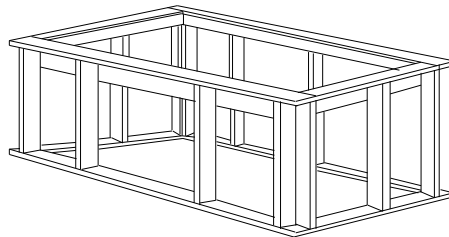

Slide the tub in place as instructed above with both the deck and bowl supported. A layer of mortar is placed under base of tub.

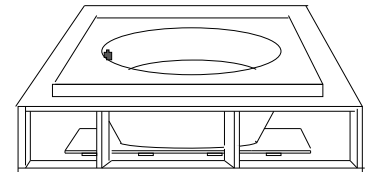

To insure proper drainage, use a 4 ft. level to level the top of bathtub in both directions, do this before mortar is dry.

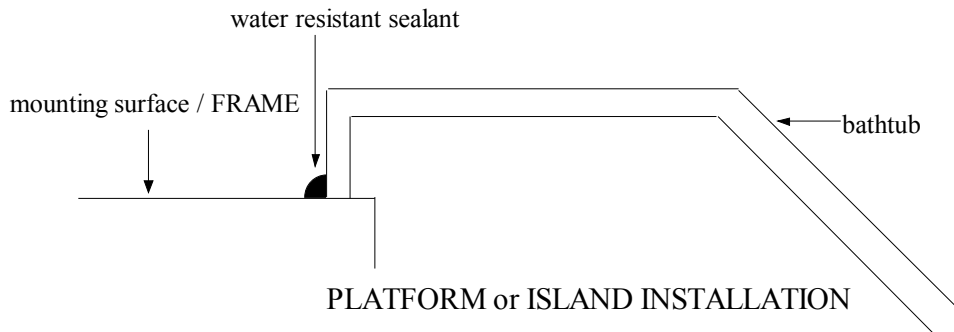

Alcove Installation

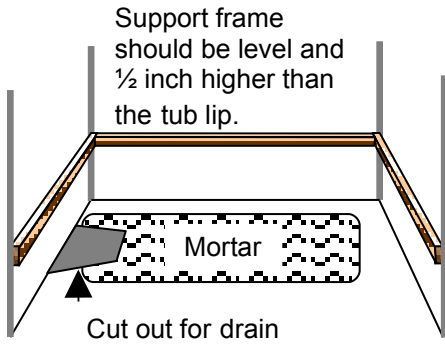

Remember: Leave an access panel opening for service access to the pump and electrical connections.

Install the tub per the instructions above and tile down to the tub deck. Finish the apron as desired.

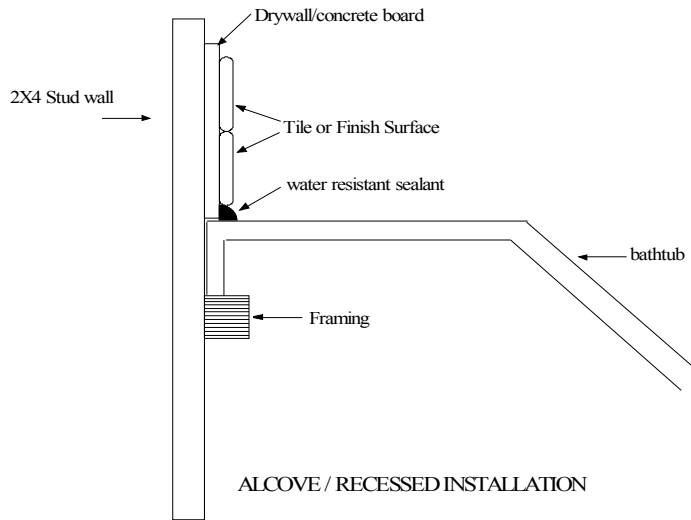
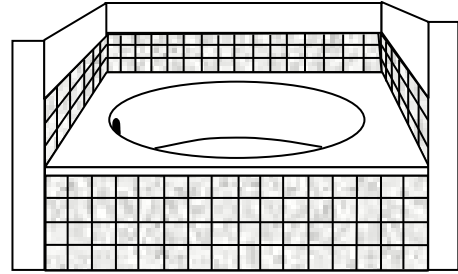

Optional Tile Flange

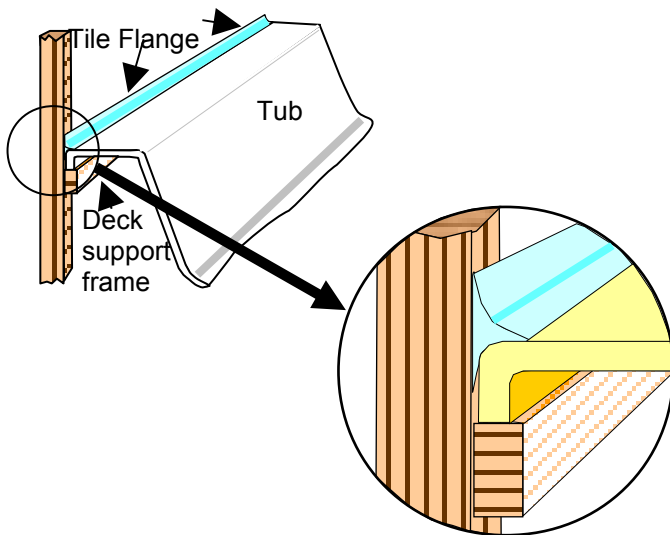

Optional Front Apron with Access Door

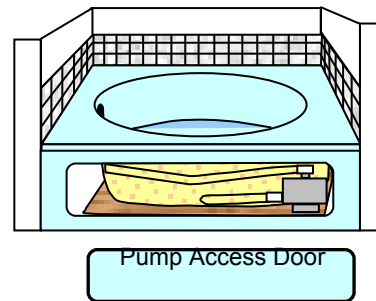

Operating your Whirlpool:

Before using your tub for the first time, clean the tub and wipe out any debris.

Fill the tub at least two inches above the highest jet before turning on the pump. Exposed jets will cause excessive splashing. **Never run the unit dry** - this can damage the pump.

Do not leave children unattended in or around an operating whirlpool.

Never have any electrical device within reach.

Never put your head under water while operating the whirlpool. Hair can be caught in suction inlet and cause injury.

High foaming agents (bubble baths) should not be used when the pump is operating. Take your whirlpool first, then use soap like a standard tub. Using oils can cause build-up in the system and may require extra cleaning.

Cleaning your Whirlpool:

For normal cleaning, use a soft sponge with warm water and cleaner. Make sure the cleaner does not contain abrasives, ammonia or any harsh additives. Many non-abrasive cleaning agents designed for plastics and fiberglass are now on the market.

One way to keep your whirlpool looking like new is with a little preventative maintenance. After using your tub, take a moment and wipe it out with a towel. This habit prevents usual film build-up. Products such as Gel-Gloss can be applied to the unit to increase and maintain the shine.

The whirlpool system should be flushed once a month using the following Procedural sequence:

- Set air controls to fully closed position.
- Fill tub with hot water until water covers jets.
- Add 2 teaspoons of a low-foaming automatic dishwasher detergent, such as Cascade, and 4 ounces of household bleach, (Clorox).
- Run whirlpool unit for 10 to 15 minutes.
- Drain tub and fill with cold water until water covers jets.
- Run whirlpool unit another 5-10 minutes then drain tub.

Trouble Shooting Guide

If there is a problem (P) with your Whirlpool, please try these solutions (S):

P: Black particles are coming out of the jets:

S: Whirlpool units not flushed on a regular basis could develop a residue in the pipes, eventually entering the whirlpool as a dark flake-like substance. If this should occur, you may need to flush the system several times, doubling the cleaning agent amounts.

P: Whirlpool won't run:

S: Verify the electrical source:

Check the circuit breakers.

Unplug cord from outlet if possible. Test status of outlet by plugging in a working electrical Appliance.

If outlet does not work contact your electrician.

If outlet works contact Manufacturer @ 1-800-795-1812

P: Scratches or cracks in finish:

S: Call Manufacturer @ 1-800-795-1812

P: Water Leaks:

S: Try to find out exactly where the tub is leaking by ruling out typical plumbing leaks: faucet, waste And overflow, or caulking around the tub. For these leaks contact your plumber. Any other leaks Call Manufacturer @ 1-800-795-1812

P: Too little or too much pressure from the jets:

S: Tighten or loosen air control knobs to regulate the pressure. Rotate the center eyeball of the jet to Redirect the water flow.

P: Any movement of the tub:

S: Check for proper installation by referring to installation instructions provided by Manufacturer.

P: Pump/Jet pressure surges (slows down then speeds up again)

S: Change direction of jets so they do not point at the suction.

Manufacturer's Customer Service Department : 1-800-795-1812

CONFIGURATION SHEET

Follow instructions pertaining to your tub configuration.

CONFIGURATION 1 One Pump Systems

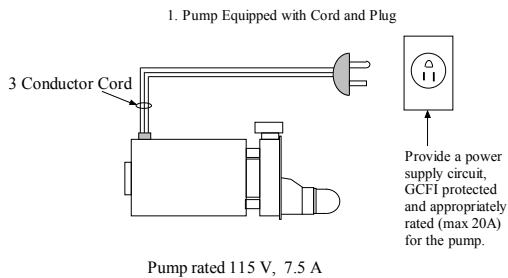

CONFIGURATION 3 1 Pump w/electronics & light

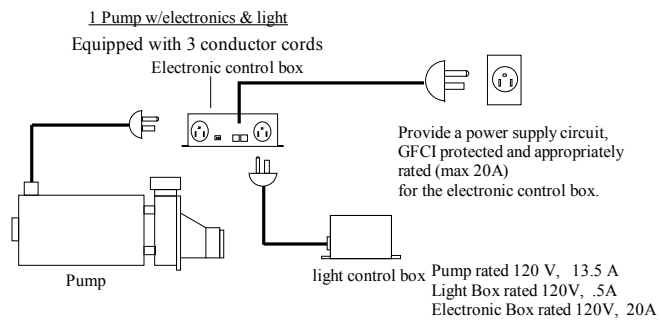

CONFIGURATION 2 Pump & Heater Systems

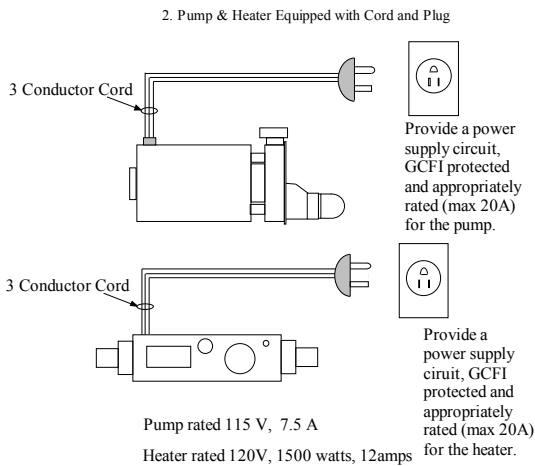

CONFIGURATION 4 1 Pump w/electronics, heater & light

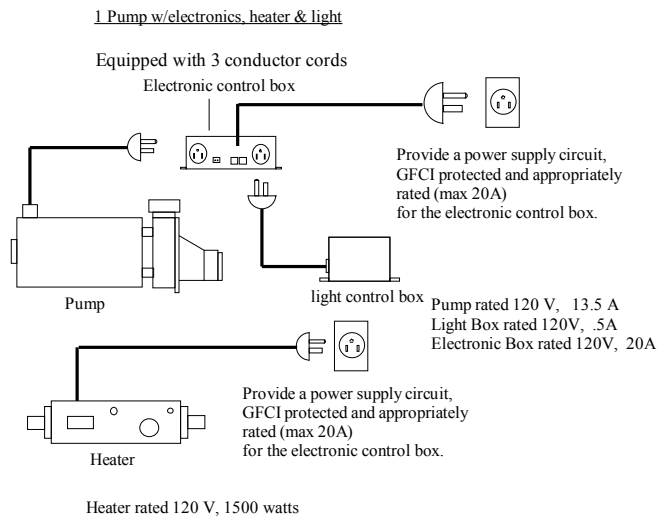

Trajert offers a wide variety of models of tubs. Just choose the diagram that best fits your whirlpool.

All Trajet whirlpools are equipped with the Safety Suction feature.

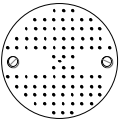

Safety Suction - This feature breaks the suction on the outflow of the tub in case anything such as a washcloth or long hair would get stuck on suction cover.

Pinnacle Series

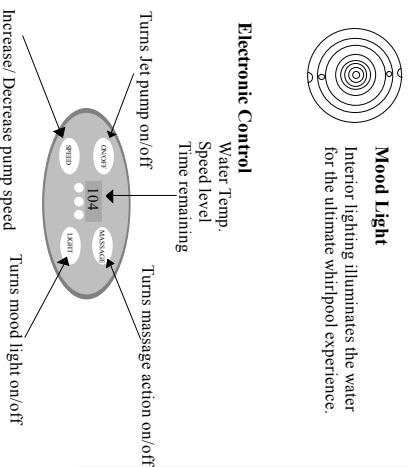

Tub model and jet system configuration may vary. Some Pinnacle Models are equipped with 1 or 2 Large Adjustable Jets

We have incorporated a "Safety Suction" feature into all of our whirlpool tubs. This feature breaks the suction on the outflow of the tub in case anything such as a washcloth or long hair would get stuck on the suction cover. This releases the obstruction so that it can be removed. The tub then resumes its normal operation.

Elite Series

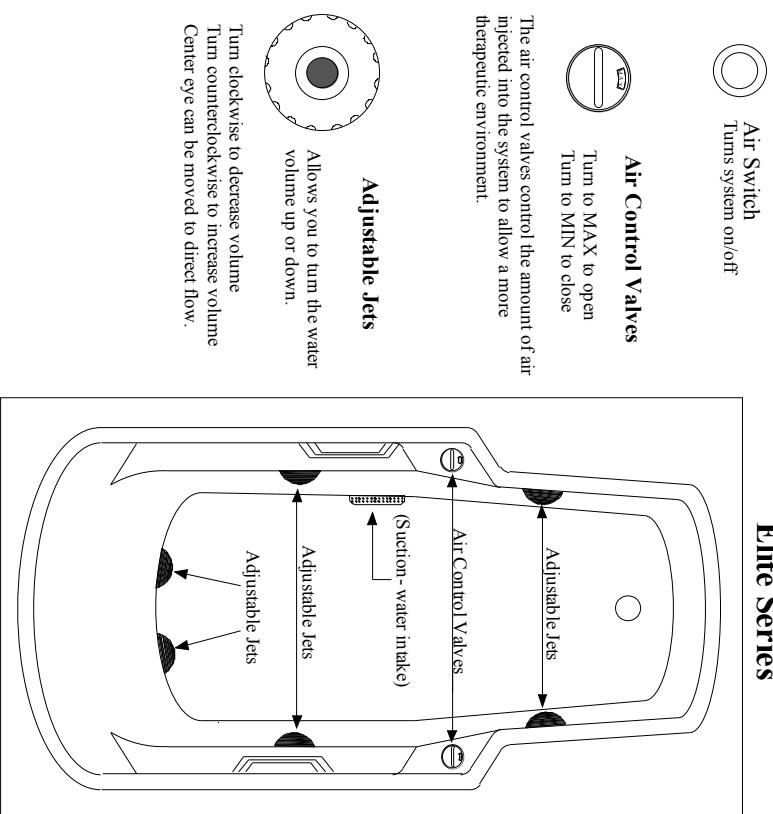

Tub model and jet system configuration may vary. All Jets on Elite Series are Adjustable

If your whirlpool bathtub is a Pinnacle series, has electronic controls and a mood light:

Digital Variable Speed Control, One Pump Version

The **Digital VSC Control** (1 pump version system) is a versatile control consisting of a Power Box, a Keypad with Digital Display, and temperature probe. It is designed to interface with universal AC motors up to 1.5 HP rating and is capable of controlling one pump plus one light via standard NEMA-style AC sockets.

Electrical Specifications

Power Input: 117 VAC +/-10% 60 HZ only 16 Amps Maximum (requires 20 AMP service connection)

Output Jet Pump: 16 Amps Maximum, Universal AC Pump motor only; do not use with AC induction motor pumps.

Output Light or auxiliary: 16 amps capable, reduced by the amount of current required by the jet pump. Therefore, if the jet pump requires 12 amps maximum, the Light outlet can supply 16-12= 4 amps maximum. When used to control a 12VAC or 24VAC low voltage lighting system, an external step-down/isolating transformer **MUST** be used. **NEVER plug a low-voltage lighting system directly into the light output socket or the lights will be destroyed!**

Input, Temperature Sensor: nominal resistance 30Kohms at 25 degrees Centigrade, custom probe.

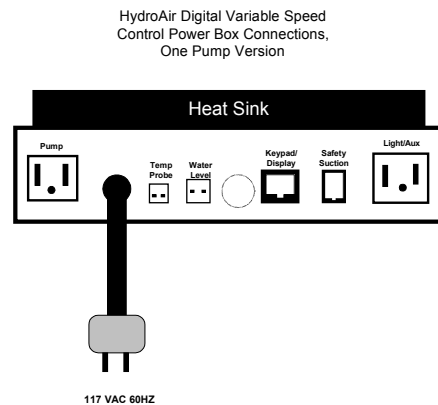

Operation

Power Turn-on: With the unit connected, the Keypad/Display will show 888 and all status indicators should be **ON** for a period of 2 seconds. This is a convenient “lamp test” function to prove all indicators are functioning. All outputs will be powered up in the “OFF” state. After two seconds, the display will revert to showing the water temperature in degrees Fahrenheit. If the temperature sensor is defective, either disconnected/open or shorted, the display will show 5n for Sensor failure instead of temperature.

ON/OFF Key: Depressing the **ON/OFF** key will activate the jet pump at the highest speed level. The pump will remain ON for maximum time of 20 minutes of operation, after which it will automatically shut off. If the jet pump is already ON, depressing the **ON/OFF** key again will turn the pump OFF.

When the jet pump is ON, the status indicator for PUMP will be illuminated. The digital display will alternate between the Water Temperature to the Speed Level (1-10) to the time remaining (1-20 minutes). Each display period lasts for 2 seconds. Thus assuming the water temperature is 104, the initial display will show **104** (water temperature) then **L10** (for speed level 10) then **t20** (for 20 minutes remaining) back to **104** etc.

Speed Adjust (UP/DN) Key: If the jet pump is OFF, depressing the **UP/DN** key has no effect. If the jet pump is ON, depressing the **UP/DN** key will change the speed on by level as follows: initially the jet pump is turned ON at L10, the highest level. If the **UP/DN** key is depressed, the level is changed to L9 and the display will show L9 for 3 seconds. If the **UP/DN** key is depressed again, the speed will lower to L8. Depressing the **UP/DN** key again will lower the speed to L7 then L6 ... down to L1, the lowest speed. If the **UP/DN** key is depressed again, the speed will increase to L2, then L3, L4...until level 10 (the highest speed) is reached again, at which time this process will be repeated.

Massage Key: If the jet pump is OFF, depressing the **MASSAGE** key has no effect. If the jet pump is ON, depressing the **MASSAGE** key will initiate the massage mode of the control. The speed will be under automatic control and will vary from

lowest to highest speed in period manner to simulate a “massage” action of the jets. This action will continue for the remainder of the 20 minute timeout period or until cancelled by either depressing the **ON/OFF** key or the **UP/DN** key.

If the **UP/DN** key is depressed, the massage mode will be cancelled and the speed will revert to one level above or below the speed that the pump was running before the Massage mode was activated. Thus if the jet pump was running at level 8 before the Massage key was depressed, it will now be at level 7. If the ON/OFF key is depressed while the Massage mode is active, the jet pump will be shut OFF immediately.

Light Key: The **Light** key turns the light output ON and OFF. It is totally independent of the rest of the system. Hence it is not dependent upon whether the water level is sufficient for normal operation or whether the jet pump is active or not. If light output is ON, the light status indicator will be ON; if the light output is OFF, the light status indicator is OFF. There is NO automatic timeout function on this output.

Troubleshooting Guide

(1) Keypad is not illuminated/non operational:

- ✓ Is the circuit breaker or power source to the system tripped?
- ✓ Is the Power Box line cord connected to a 120VAC?
- ✓ Is the keypad plugged into the Power Box?
- ✓ Is the cable going from the Keypad to the power box connected at the keypad end?

(2) Keypad is illuminated but pump does not operate when the ON/OFF key is depressed:

- ✓ Does the Display show alternating temperature→speed→time remaining? If true, go to (3) below
- ✓ Is the water level sensor connected to the Power Box and the tub have sufficient water level to cover the sensor probes?

If there is no water level sensor, is a shorting jumper connected to the water level sensor input.

(3) Keypad shows that the jet pump is active, but the pump is not ON:

- ✓ Is the jet pump connected to the correct outlet of the power box?
- ✓ Is the pump motor hot? Possibly the thermal protection has tripped, in which it will probably cool down and begin operation again.
- ✓ Measure the pump outlet socket with a voltmeter: if voltage is present, then possibly the pump is defective. Note: the pump outlet is controlled by a triac; if no load is connected and a DVM is used to measure AC voltage, please be aware that there is sufficient leakage current through the triac and associated snubber network to read almost full line voltage when the outlet is still in the OFF state; if using a DVM, insure a pump load is connected to the outlet before measuring.

(4) Jet pump overheats and shutdown within a few minutes of activating the MASSAGE key:

Be sure the jet pump motor is a Universal motor; the power box cannot be used with an AC induction motor.

(5) The light is not illuminated when the LIGHT key and status indicator are ON:

- ✓ Is a step-down transformer connected to the LIGHT socket?
- ✓ Measure the secondary output of the transformer: is it about 14VAC for a 12 V system? If no, possibly the transformer is defective.
- ✓ Are the lights possibly burned out or not connected to the transformer?

(6) The pump is off; when I depress the MASSAGE key, nothing happens:

- ✓ The Jet Pump must be ON first by depressing the **ON/OFF** key. The **Message** Key only enables or disables massage when the pump is ON.

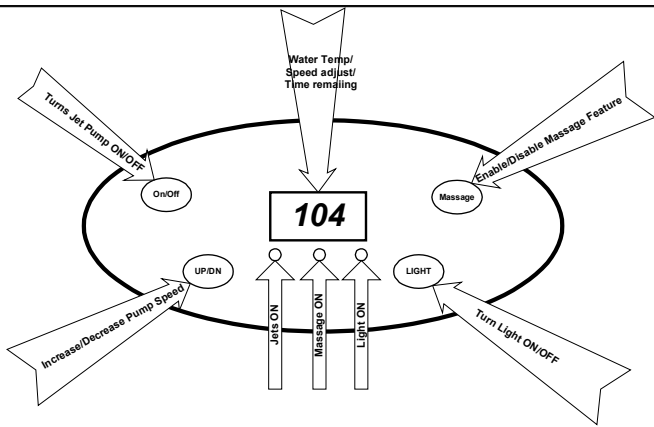

Figure 2- Keypad /Display Functions

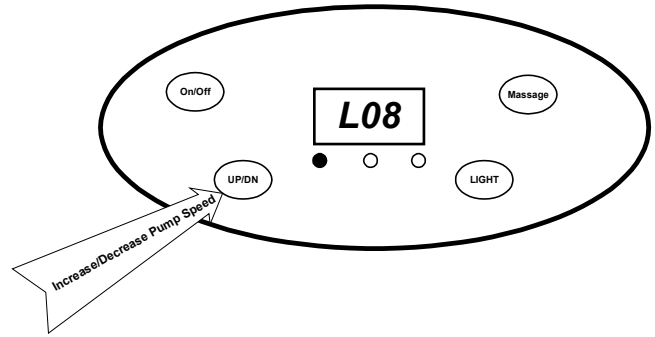

Figure 5- Speed Adjustment

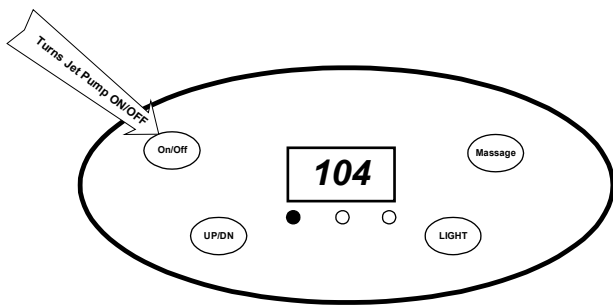

Figure 3- Pump ON

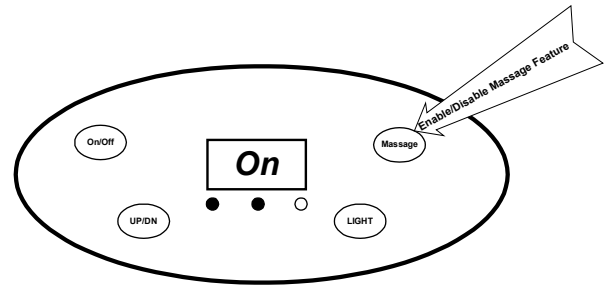

Figure 6- Activate Massage

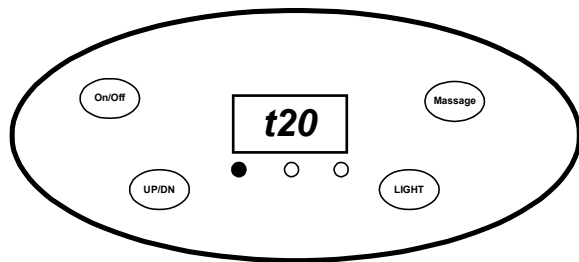

Figure 4- Time Remaining

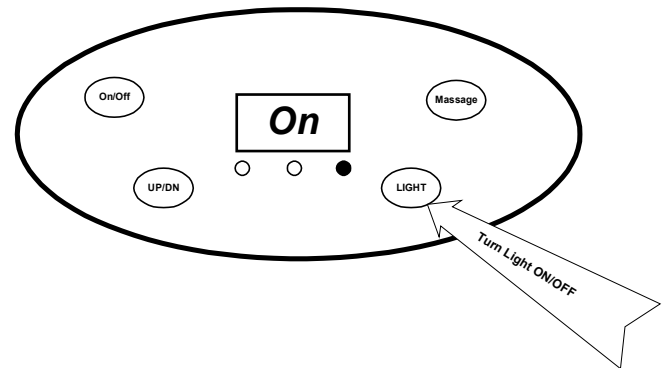

Figure 7- Light ON/OFF